

OVERCONFIDENCE, SOCIAL GROUPS, AND GENDER: EVIDENCE FROM THE LAB AND FIELD

Andrew Healy^{*}
Loyola Marymount University

Jennifer Offenberg[†]
Loyola Marymount University

April 14, 2007[‡]

Previous research indicates that economic agents incorrectly believe that they will perform better than others in a variety of environments. This paper investigates whether a similar phenomenon exists for social groups. Students participating in a lab experiment and Scrabble players participating in a tournament revealed their beliefs about their own performances and their friends' performances. On average, the lab and field subjects both show similar levels of confidence in themselves and in their social groups. Behind these similar average levels of confidence lie some striking gender differences. In both the lab and the field, female subjects tend to show greater confidence in their groups than in themselves, while male subjects show greater confidence in themselves than in their groups.

Keywords: laboratory experiment, field experiment, overconfidence, groups, gender
JEL codes: C90, C93, L0, J16

^{*} Corresponding author: Department of Economics, Loyola Marymount University, 1 LMU Drive, Los Angeles, CA 90045; e-mail: ahealy@lmu.edu

[†] e-mail: joffenberg@lmu.edu

[‡] We thank Gary Charness, Jacob Goeree, Dorothea Herreiner, James Konow, Chinda Wongngamnit and participants at the 2006 ESA North American meeting for helpful discussions. We thank Helen Mathur of Major Tests and the College Board for allowing us to use their questions in our experiment. Stephen Salinas and Gena Gammie provided excellent research assistance. This project was funded by a research grant from Loyola Marymount University and we gratefully acknowledge their support.

I. Introduction

People display overconfidence in themselves in a wide variety of environments. Eighty percent of individuals rate themselves in the top thirty percent of drivers (Svenson, 1981). Students often incorrectly think that they will perform better than other students on general-knowledge tests (Camerer and Lovo, 1999; Gigerenzer et al., 1991). Although incentives, task difficulty, and ambiguity mitigate or amplify confidence, it seems clear that, in certain lab environments, overconfidence is present. The presence of overconfidence has important implications both for real-world behavior and theory. For example, overconfidence appears to affect behavior in financial markets, leading some investors to trade too much (Barber and Odean, 2001; Daniel et al., 1998). In addition, recent theoretical research has looked at how overconfidence may affect an individual's willingness to exert effort or to learn information about her ability (Benabou and Tirole, 2002; Koszegi, 2005).¹ All of this experimental and theoretical research defines overconfidence in terms of an individual's perception of her own ability or performance.

This paper departs from previous research on overconfidence by looking at whether or not individuals are overconfident in the performance of their group as compared to their individual performances and the performances of other groups. We might expect such overconfidence to be present for a variety of reasons. A business has an interest in maintaining employee morale and so often fosters the impression that the organization is of high quality. An

¹Hoelzl and Rustichini (2005) show that paying subjects tends to reduce self-reported overconfidence. Perloff and Fetzer (1986) and Hoorens and Buunk (1993) indicate that overconfidence can be significantly reduced by making the target of comparison clearer. Dunning, Meyerowitz, and Holzberg (1989) and Greico and Hogarth (2004) describe the relationship between ambiguity and measures of overconfidence. Overconfidence clearly does not exist in all environments. For example, individuals are generally underconfident when faced with a large amount of weak evidence that supports a statistical hypothesis, reflecting an underreaction to the weight of a body of evidence (Griffin and Tversky, 1992).

individual may devote more time and energy to her group activities when she believes in her organization.² The tendency for an employee to hold a large share of her savings in her own firm's equities is consistent with the hypothesis that individuals display overconfidence not just in themselves, but also in their groups.

The presence of group overconfidence would have implications for how organizations work. For example, a manager who is overconfident in her social group may put less effort into looking outside her social group when searching for a new employee. Overconfidence may bias her perceptions of job candidates in favor of her group members. Such a phenomenon would help to explain why managers often hire individuals to whom they are connected in some way.³ Group overconfidence also may explain why decision-making groups often fail to draw on valuable outside information, even when that information could easily be obtained. The Kennedy administration's failure to consult the CIA or State Department when planning the Bay of Pigs invasion and the decision of management at NASA to ignore outside advice about the danger of the 1986 Challenger launch both illustrate problems that can occur when groups think they know more than they really do (Janis, 1972; Surowiecki, 2004).

This paper presents lab and field evidence that tests the hypothesis that people are overconfident in their social groups. In the lab experiment, ten student organizations were recruited to participate in an experiment in which subjects took a math test and operated a fictional lemonade stand. Each subject answered questions that elicited her beliefs about her performance on the task relative to other students and also the performance of her other group

²See Norsworthy and Zabala (1985) for evidence that worker morale positively affects productivity in the US auto industry.

³Montgomery (1991) estimates that about half of jobs are found through social connections. A variety of explanations have been offered to explain the preference for one's own group members other than the overconfidence explanation suggested here. Wanous (1980) argues that connected individuals have a better idea of the job's requirements and so are more likely to apply. Doeringer and Piore (1971) and Montgomery (1991) argue that referrals reduce uncertainty and so mitigate adverse selection problems with job applicants.

members. On average, subjects show similar levels of confidence in their own performances as they do in their groups. On the math test, subjects show slightly greater confidence in themselves than in their groups, but the difference is not significant.

Beyond these results for average individual and group confidence, we found significant gender differences in subject behavior. The results for individual confidence are consistent with previous findings that men are significantly more confident than women in their own performances (Barber and Odean, 2001). Despite being significantly less confident in themselves than men, women show slightly more confidence in their groups, although the difference in group confidence is not significant.

In the field data, participants in a Scrabble tournament revealed their expectations about the number of games they expected to win and the number of games they expected their friends to win. The Scrabble players show overconfidence in their own and their friends' performances. In this environment, men and women tend to show the same levels of confidence in their own performances, but women show significantly more confidence in their friends' performances when compared to men. Two consistent findings thus emerge from both the lab and field data. First, the overall magnitudes of individual and group confidence are approximately the same. Second, compared to men, women show relatively more confidence in their groups than in themselves.

Recent research shows that women often choose not to compete even when their chances of success are high, while men often compete when their chances of success are low (Niederle and Vesterlund, 2006). The results in this paper suggest that competitions based on group performance as opposed to individual performance may help to solve both inefficiencies.

The paper proceeds as follows. The design of the lab experiment is described in Section

II. Section III summarizes the lab data and reports the results relating to it. In Section IV, we describe the field data and report the relevant results. Section V discusses the implications of the results and concludes.

II. Experimental Design

The lab experiment extends the designs employed by Camerer and Lovallo (1999) and Hoelzl and Rustichini (2005). Subjects in those experiments reveal their expectations about their performances by answering choice questions.

In Hoelzl and Rustichini (2005), subjects take a vocabulary test. Before taking the test, they choose whether they want their payment to be randomly determined or to be determined by whether they rank in the top half of subjects who take the test. Like Camerer and Lovallo's (1999) procedure, their design measures overconfidence without relying on self-reported measures. The design that we employ draws from each of these papers and additionally elicits a subject's confidence in her group.

II.A. Procedure

A total of 101 subjects, 65 women and 36 men, participated in the lab experiment. Each student was recruited from one of ten student groups. Four of the organizations were sororities or fraternities, with the former being all-female social organizations and the latter being all-male groups. Another four organizations were community service clubs, which are similar to sororities and fraternities, but consider service activities to be their primary focus. The final two organizations were a sports team and a group of high performing students who take classes together. The sports team has separate male and female teams that travel together to

competitions. The experiment took approximately 45 minutes, with payments averaging \$15 per subject. We conducted a total of eight experimental sessions.

In the experiment, subjects took a math test and ran a fictional lemonade stand. The sequence of the tasks was varied to test for order effects. On the math test task, subjects answered six questions that were taken from SAT preparatory material. For the lemonade stand task, subjects faced three situations with different weather conditions and input costs. They needed to decide how many cups of lemonade to produce and what price to charge in each situation, with the goal of maximizing total profit across the three situations.⁴

Subjects answered a series of choice questions about how they believed they would perform. The subjects were told that one of the questions that they answered would be selected at random to determine their payment, and that they could receive \$5 depending on the outcome for that question. Each question was structured in the same way. The first question is described in Table 1.

Table 1: Sample choice question from the experiment

Option 1: You win if you correctly call a coin flip. In other words, you have a 50% chance of winning. If you choose this option, we will give you a 50% chance of winning

Option 2: You win if your performance on the lemonade stand task is better than half of the other students in all sessions of the experiment. It makes sense to choose Option 2 if you think there's a better than 50% chance that your profit will be in the top half of all profits. Any ties will be randomly broken.

Your choice (Circle one): Option 1 Option 2

This choice question in Table 1 elicited a subject's confidence in her own performance

⁴ The complete set of sample problems and sample situations for the two tasks can be found in the Appendix.

relative to all others, which we refer to as individual confidence. In the second choice question, Option 2 asked the subject to compare the performance of her group's median member to all other students, which we refer to as group confidence. The students were told the names of all the groups participating in the experiment. They were instructed that there were no correct answers to the choice questions, and that they should just answer in a way that reflected what they believed would happen on the task.

To make it possible to do the comparisons needed to determine payments for the choice questions, payments were calculated after all experimental sessions were completed. Subjects returned to the lab at a later date to receive payments based on an identification number they were assigned during the experiment.

II.B. Equilibrium predictions

In equilibrium, 50% of subjects should choose Option 2 when choosing whether to bet on themselves relative to all other students. Likewise, 50% of students should choose to bet on their group relative to all others. In each case, if subjects predict their own performances and their groups' performances with noise, but are generally not overconfident or underconfident, half of the subjects will think that their performance or their group's performance will be better than the median.

A subject who believes she or her group will perform badly on the task reveals that belief by choosing to bet on a random device rather than on her individual or group performance. In other words, it is never in a subject's best interest to deliberately obtain a low profit to validate a prediction of poor performance. Regardless of their predictions, the payoff structure is such that a subject always wants to maximize the number of problems they answer correctly on the math

test and their total profits on the lemonade stand task.

III. Lab Results

Table 2 shows the general results for individual and group confidence. For the math test, 63% of subjects believed they would finish in the top half of subjects in the experiment. A slightly smaller share of subjects (57%) believed that their group would finish ahead of the median subject, and a Mann-Whitney test shows that the difference between the two is not statistically significant ($p = 0.39$). For the lemonade stand task, the correspondence between individual and group confidence is even closer, with 47% of subjects believing that they would do better than the median subject and the same share believing their group would do better than the median subject.

Table 2: Confidence revealed by choice behavior

Question	Share that believes it will finish in the top half	95% confidence interval
<i>I. Math test</i>		
Comparing self to all other subjects	0.63	(0.53,0.72)
Comparing self to other group members	0.57	(0.48,0.66)
Comparing group to all other subjects	0.57	(0.48,0.66)
<i>II. Lemonade stand task</i>		
Comparing self to all other subjects	0.47	(0.37,0.55)
Comparing self to other group members	0.59	(0.50,0.68)
Comparing group to all other subjects	0.47	(0.37,0.55)

Note: The share that believes it will finish in the top half is determined by the number of subjects who choose Option 2 in the choice tasks. Confidence intervals are calculated using percentiles of the binomial distribution.

The data show that the subjects were significantly more confident in themselves on the math test than on the lemonade stand task ($p = 0.017$). The lower average confidence on the lemonade stand task is consistent with subjects' perceptions, discussed in exit interviews, that the lemonade stand task was unfamiliar. These results of a small decrease in confidence on the unfamiliar task match with what Hoelzl and Rustichini (2005) find using a similar experimental design.⁵ The data also suggest that subjects show more confidence in their groups on the math test, but that difference is not statistically significant ($p = 0.122$).

While we will focus on a subject's confidence in herself and their groups in comparison

to all other subjects, we also elicited a subject's confidence in herself compared to her other group members. On the math test, subjects show slightly less confidence (57%) when they are comparing themselves to their other group members. This finding matches with Klar and Giladi's (1997) result that overconfidence diminishes when the target of comparison becomes more well-defined. On the other hand, on the lemonade stand task, subjects show somewhat more confidence when comparing themselves to their other group members (59%) than when comparing themselves to all other subjects, although the difference is not significant at the 5% level ($p = 0.068$). Notice that confidence relative to one's group members changes the least across the two tasks. This result is not strong enough to permit firm conclusions, but does suggest that confidence may be less sensitive to the experimental environment when the target of comparison are people with whom the subject has a personal connection.

III.A. Measuring overconfidence

The measures in the previous section describe how confident individuals are in themselves and in their groups. Given multiple measures of confidence, it is possible to see which is more often justified: confidence in oneself or confidence in one's group. Subjects may have an advantage in predicting their own performance because they know themselves better than they know their groups. On the other hand, it may be easier to predict the group's performance because averaging across the group minimizes the effect of randomness in any one individual's performance. These competing effects may also cancel each other out.

Table 3 displays how often subjects choose correctly. A subject who chose option 1

⁵Hoelzl and Rustichini (2005) disagree with a large body of previous research that concludes that overconfidence increases with task difficulty. This literature is summarized in Griffin and Tversky (1992). There is no obvious way to reconcile these differences, except to note the contrast in incentives between the different experiments.

chose correctly if she or her group did not finish above the median student. A subject who chose option 2 chose correctly if she or her group did finish above the median student.

Table 3: Confidence: Justified or unjustified?

	Finished in lower half	Finished in top half	Share who chose optimally
I. Math Test			
<i>Overconfidence in oneself compared to all others</i>			
Chose Option 1 (Not confident): 37 subjects	73%	27%	67%
Chose Option 2 (Confident): 64 subjects	36%	64%	
<i>Overconfidence in group compared to other groups</i>			
Chose Option 1 (Not confident): 43 subjects	72%	28%	63%
Chose Option 2 (Confident): 58 subjects	43%	57%	
II. Lemonade Stand Task			
<i>Overconfidence in oneself compared to all others</i>			
Chose Option 1 (Not confident): 54 subjects	46%	54%	46%
Chose Option 2 (Confident): 47 subjects	54%	46%	
<i>Overconfidence in group compared to other groups</i>			
Chose Option 1 (Not confident): 54 subjects	48%	52%	48%
Chose Option 2 (Confident): 47 subjects	53%	47%	

*Ties are broken randomly. For example, 21 of the students who answered three questions correctly received payment and 6 did not, so that half of the students received payment. When calculating the values in the table, subjects who finished in a tie are counted according to the probability of receiving payment.

Table 3 shows that subjects are equally accurate in predicting their own performances and their groups' performances. In each case, subjects are right about half of the time. The fact

that subjects do not do a particularly good job at predicting their own performances is consistent with research in psychology suggesting that overconfidence may detract from a subject's performance on a task (Renner and Renner, 2001). Still, the absence of a correlation between performance and expectations may not generalize to other tasks. In fact, our field data shows a significant correlation between performance and expectations, which we discuss later in greater detail.

III.B. Confidence and gender

Prior research indicates that overconfidence and gender are closely related (Barber and Odean, 2001; Bengtsson, Persson, and Willenhag, 2003). Barber and Odean (2001) find that men are significantly more confident in their abilities to predict stock performance. As a result, men trade excessively and realize smaller overall returns than women. The results in this paper confirm that, across both tasks, men are significantly more confident and more prone to overconfidence when predicting their performances than are women. These differences disappear, however, when women and men are asked to predict their groups' performances. In terms of group overconfidence, men and women are generally similar, although there is some evidence that women may be more prone to group overconfidence than men.

Table 4 breaks down confidence by gender. On the math test, 89% of male subjects believe they will beat the median subject, even though only 67% do, demonstrating that men show a tendency towards individual overconfidence. On the lemonade stand task, 61% of male subjects believe they will beat the median subject, and only 50% do. Pooled across the two tasks, male subjects believe they will beat the median subject 74% of the time and they beat the median subject 58% of the time, a marginally significant difference ($p = 0.053$).

Table 4: Confidence revealed by choice behavior, by gender

Question	Share that believes it will finish in the top half	Share that did finish in the top half
I. Skills test		
<i>Female subjects (65 subjects)</i>		
Comparing self to all other subjects	0.49 (0.37,0.61)	0.40
Comparing group to all other subjects	0.51 (0.39,0.63)	0.17
<i>Male subjects (36 subjects)</i>		
Comparing self to all other subjects	0.89 (0.77,0.98)	0.67
Comparing group to all other subjects	0.69 (0.54,0.84)	0.94
II. Lemonade stand task		
<i>Female subjects (65 subjects)</i>		
Comparing self to all other subjects	0.38 (0.27,0.50)	0.49
Comparing group to all other subjects	0.49 (0.37,0.61)	0.49
<i>Male subjects (36 subjects)</i>		
Comparing self to all other subjects	0.61 (0.45,0.77)	0.50
Comparing group to all other subjects	0.42 (0.26,0.58)	0.50

Notes: (1) 95% confidence intervals, constructed from the binomial distribution, are in parentheses. In the choice problems, a subject who chose option 1 chose to be paid based on a random device. A subject who chose option 2 chose to be paid based on either her own or her group's performance.

Women, in contrast, do not show a tendency towards individual overconfidence. On the

math test, female subjects believe they will perform better than the median 49% of the time, and they do 40% of the time. For the lemonade stand task, 38% of women believed they would beat the median and 49% of them do. Pooled across the two tasks, women believe they will perform better than the median subject 44% of the time, and they beat the median subject 45% of the time.

For overconfidence in one's group, the gender differences change substantially. On the math test, 69% of male subjects bet on their groups to beat the median, while 94% of them are in groups that beat the median, suggesting that men would benefit by being even more confident in their groups. While 51% of female subjects bet on their groups, only 17% of women are in groups that beat the median, suggesting that women would benefit by being less confident in their groups. For the math test, the gender comparisons are complicated by the fact that men do somewhat better than women on the task, and male groups significantly outperform female groups. As a result, we will focus primarily on the lemonade stand task, where the differences in male and female overconfidence are smaller, but the interpretation is more straightforward, given that there is no difference in performance across genders.

On the lemonade stand task, 49% of women choose to bet on their groups, which is the same percentage of women whose groups finish in the top half. In contrast, only 42% of men choose to bet on their groups, while 50% of them would have won had they done so. This finding suggests that men would perform slightly better by betting more often on their groups, although the hypothesis that the percentage of men who bet on themselves is 50% cannot be rejected ($p = 0.48$).

However, the differences between individual and group overconfidence for men and women are definitely not the same. While 61% of men show confidence in themselves, only

42% of men show confidence in their groups, making men 19% more likely to believe in themselves than in their groups. In contrast, women are 11% more likely to believe in their groups than in themselves, and the difference between the two is significant ($p = 0.02$). These differences are summarized in Table 5. For the lemonade stand task, the data provide two significant results. First, consistent with previous research, men show more confidence in their individual performances than women. Second, the relative differences between individual and group overconfidence for men and women are also different. This result is derived from men and women having roughly similar levels of group confidence, with men being significantly more prone to individual overconfidence. Insight into these results is gained by comparing the single sex groups to groups that contain both men and women, as shown in Table 6.

Table 5: Hypothesis tests for lab data (lemonade stand task)

I. Comparing individual and group confidence

Hypothesis 1: Across all subjects, individual confidence (47%) = group confidence (47%)
 $p = 1.00$, $N = 202$ (101 individual predictions, 101 group predictions)

II. Comparing male and female confidence

Hypothesis 2: Female individual confidence (38%) = Male individual confidence (61%)
 $p = 0.03$, $N = 101$

Hypothesis 3: Female group confidence (49%) = Male group confidence (42%)
 $p = 0.47$, $N = 101$

Hypothesis 4: Female group confidence (49%) - Female individual confidence (38%) =
Male group confidence (42%) - Male individual confidence (61%)
 $p = 0.02$, $N = 101$

Note: All p -values come from Mann-Whitney tests.

Table 6: Confidence in single sex and co-ed groups

Question	Percent that believes it will finish in the top half	Percent that did finish in the top half
<i>I. Subjects in single sex groups</i>		
<i>Female subjects (43 subjects)</i>		
Comparing self to all other subjects	30% (17%,44%)	53%
Comparing group to all other subjects	35% (21%,50%)	58%
<i>Male subjects (19 subjects)</i>		
Comparing self to all other subjects	53% (30%,75%)	47%
Comparing group to all other subjects	42% (20%,65%)	58%
<i>II. Subjects in co-ed groups</i>		
<i>Female subjects (22 subjects)</i>		
Comparing self to all other subjects	55% (34%,75%)	43%
Comparing group to all other subjects	77% (58%,93%)	36%
<i>Male subjects (17 subjects)</i>		
Comparing self to all other subjects	71% (47%,91%)	53%
Comparing group to all other subjects	41% (18%,65%)	36%

95% confidence intervals, constructed from the binomial distribution, are in parentheses.

In the choice problems, a subject who chose Option 1 chose to be paid based on a random device.

A subject who chose Option 2 chose to be paid based on either her own or her group's performance.

Caution should be exercised when looking at the last column, since some of the average group profits were very close to the median subject's profit. In both single-sex and co-ed groups, men believe more in themselves relative to their groups, while women believe more in their groups relative to themselves. The differences between men and women are particularly large for the three co-ed groups. Here, 71% of men and 55% of women in these groups believe their individual performance will place them in the top half of all subjects. This finding is reversed when subjects evaluate their group performance, where 77% of women think their group will beat the median, while only 41% of men predict this outcome.

The results seen in Table 6 are open to two interpretations. One hypothesis is that women believe more in their groups than themselves and particularly believe more in co-ed groups. A second hypothesis is that women have high confidence in men, with the group issue being of lesser importance. In other words, women may either have high confidence in co-ed groups or they may have high confidence in male individuals. Conversely, men may lack confidence in co-ed groups or they may lack confidence in women. The field data presented in Section IV provides evidence supporting the first hypothesis and in contradiction to the second. In the field data, women believe significantly more in their groups than men do, and the women show high confidence both in their female and male group members.

IV. Field Results

IV.A. Experimental design

To test for the generality of the results from the lab experiment, we conducted a simple experiment to elicit the perceptions of Scrabble players before a major tournament in Reno, Nevada, in July 2006. Scrabble is a board game in which players compete to make the highest-

scoring words. The tournament version of Scrabble involves head-to-head competition. Much like competitive chess players, competitive Scrabble players have ratings that reflect their performance in tournaments and many play regularly in clubs and online. In contrast to chess, many competitive Scrabble players are female, although most of the highest-rated players are male.⁶

In the Reno tournament, 96 players competed in four different skill divisions, and 74 participated in the experiment. These 74 players received \$2 for filling out a one-page questionnaire. In the questionnaire, a player revealed how many games they thought they would win and how many games they believed up to three of their friends would win, out of the 28 games that each player would play in the tournament. Players also answered questions about how they believed players from their clubs would perform in the tournament. Participants were informed that five subjects would be chosen at random to be paid based on the number of correct predictions that were made, with the chosen subjects receiving \$4 for each correct prediction. The survey took subjects three to five minutes to complete.

IV.B. Results

Scrabble players show significant levels of overconfidence in their individual performances. 73% of participants believe they are going to win more games than they actually do. Almost identical shares of male and female players over-predict their wins. Exactly 21 of the 29 women (72%) and 33 of the 45 men (73%) believe they will win more games than they actually do. This behavior contrasts with the lab experiment, in which men showed significantly more individual overconfidence than women. This difference between the subjects in the lab

⁶As of October 2006, only one of the top fifty rated Scrabble players in North America was female. In the past, though, a woman has won the U.S. National Scrabble Championship. Rita Norr captured the title in 1987.

experiment and the Scrabble players is perhaps not surprising, given the competitive nature of individuals who choose to travel to Reno to compete in a Scrabble tournament.

Despite the different environment, female Scrabble players still reveal more confidence in their friends than in themselves, the same behavior shown by the female lab subjects. Likewise, male Scrabble players, like the male lab subjects, have less confidence in their friends than in themselves. The 29 women in the sample make a total of 77 predictions for their friends. The women predict that their friends will win more games than they do in 64 of the 77 predictions (83%). In contrast, the 45 men overpredict their friends' wins in only 81 of 122 cases (66%). Table 7 summarizes these results.

Table 7: Scrabble players' individual and group confidence

	Percentage of players who predict too many wins
<i>Female players</i>	
Prediction for own wins (29 players)	72% (55%,86%)
Predictions for friends' wins (77 predictions)	83% (74%,91%)
<i>Male players</i>	
Prediction for own wins (45 players)	73% (58%,84%)
Predictions for friends' wins (122 predictions)	66% (58%,75%)

Note: 95% confidence intervals, constructed from the binomial distribution, are in parentheses.

Just as in the lab data, individual and group overconfidence are about the same. 73% of players in the sample are overconfident in themselves and 73% are overconfident in their friends. The data suggest that group confidence would be slightly higher if there were equal numbers of men and women in the sample. After adjusting the data to control for this issue, group confidence rises to 75%. Nevertheless, across all players, individual and group overconfidence are nearly the same, no matter how each quantity is measured, and the hypothesis that individual and group confidence are the same cannot be rejected ($p = 0.98$).

Also, the hypothesis that men and women have the same levels of confidence in their own performances cannot be rejected ($p = 0.93$). In contrast, the hypothesis that men and women have the same overconfidence in their friends is rejected ($p = 0.01$); women show significantly more group confidence than men. Table 8 shows the results of all hypothesis tests for the Scrabble data.

Table 8: Hypothesis tests for field data

I. Comparing individual and group confidence

Hypothesis 1: Across all subjects, individual confidence (73%) = group confidence (73%)
 $p = 0.98$, $N = 273$ (74 individual predictions, 199 group predictions)

II. Comparing male and female confidence

Hypothesis 2: Female individual confidence (72%) = Male individual confidence (73%)
 $p = 0.93$, $N = 74$

Hypothesis 3: Female group confidence (83%) = Male group confidence (66%)
 $p = 0.01$, $N = 199$

Hypothesis 4: Female group confidence (83%) - Female individual confidence (72%) =
Male group confidence (73%) - Male individual confidence (66%)
 $p = 0.01$, $N = 199$

Notes: All p - values come from linear regressions that account for dependence in the multiple predictions made by individual players. In the absence of dependence, these linear regressions give p -values that are almost identical to those given by Mann-Whitney tests.

The findings summarized in Hypotheses 2 and 3 contrast with the lab results. In the lab data, male subjects showed significantly more individual confidence than female subjects. Women showed more group confidence than men, but the difference was insignificant. Among Scrabble players, on the other hand, female and male players show the same amount of confidence in their own performances, but women show significantly more confidence in their groups. In both environments, women show a significantly greater tendency to group overconfidence than individual overconfidence, in comparison to men. This finding corresponds to Hypothesis 4 in Table 8.

The greater female tendency towards group confidence over individual confidence comes about in two different ways. In the lab data, men show more individual confidence than women,

but that gap disappears for group confidence. In the Scrabble data, men show the same individual confidence as women, but significantly less confidence in their friends. Across two environments with very different gender results for individual confidence, women believe significantly more in their groups relative to themselves, in comparison to men.

IV.C. Alternative explanations

The lab results relating to differences in group confidence between men and women were driven mainly by co-ed groups. Men had particularly low confidence in co-ed groups and women had particularly high confidence in co-ed groups. This finding leaves the lab data open to the interpretation that women simply have higher confidence in male group members, with men having lesser confidence in female group members. The Scrabble data provides an opportunity to test this explanation against the alternative that, compared to men, women generally have greater confidence in their groups than in themselves.

As Table 9 shows, the Scrabble data indicates that women generally believe more in their friends, whether they are female or male.

Table 9: Confidence in female and male players

	Percentage of players who predict too many wins
<i>Predictions made by female players</i>	
Predictions for other females' wins (43 predictions)	86% (74%,95%)
Predictions for males' wins (34 predictions)	79% (65%,91%)
<i>Predictions made by male players</i>	
Predictions about females' wins (33 predictions)	67% (48%,82%)
Predictions for other males' wins (89 predictions)	66% (56%,75%)

Note: 95% confidence intervals, constructed from the binomial distribution, are in parentheses.

The female Scrabble players are about 7% more likely to be overconfident in their female friends than in their male friends, while the male players are equally likely to be overconfident in their male and female friends. In 37 of 43 predictions (86%), women predict that other women will perform better than they actually do. Women are overconfident about their male friends in 27 of 34 predictions (79%), an insignificant difference. Men are overconfident for 59 of their 89 predictions (66%) about their male friends' performances and overconfident about their female friends' performances in 22 of 33 predictions (67%). The Scrabble data indicates that women do not particularly believe more in just their male friends. Instead, the hypothesis that women generally have more confidence in their social groups than men is supported by evidence from both the lab and field data.

V. Discussion

The existing overconfidence literature has focused on an individual's propensity to incorrectly believe that she is better than others. In this paper, we examined whether a similar phenomenon exists for social groups. Evidence from both the lab and the field show that confidence in one's group parallels confidence in oneself when choices are averaged over the entire sample. Underlying those average results are significant differences between the attitudes of men and women. Figure 1 illustrates how this finding holds both for the subjects in the lab experiment and the Scrabble players in the field experiment.

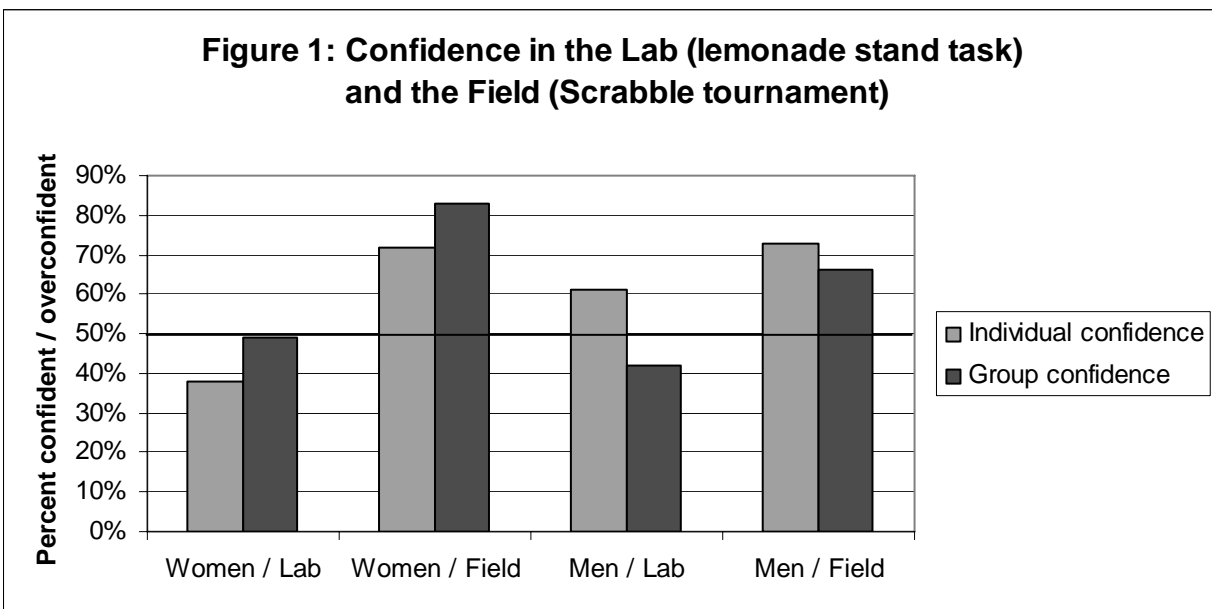

V.A. Welfare and group confidence

Would eliminating group overconfidence be welfare improving? While productivity or effort might decline if less confidence caused groups to become less tight-knit (Norsworthy and Zabala, 1985; Benabou and Tirole, 2002), other evidence suggests the opposite. Sociological research suggests that close-knit groups choose to not interact with other groups, leading to

overall social fragmentation. Granovetter (1973), for example, provides evidence that welfare may be enhanced if individuals form wide networks of loose ties rather than narrow networks consisting of close relationships.

Overconfidence in one's group may also explain some policy problems that have arisen when groups fail to consult outside sources of information (Healy, 2006). For example, management at Apple Computer isolated itself from outside information in the mid-1990s, years in which its market share declined significantly (Landry, 1997; Burrows, 2000).⁷ Overconfidence in these groups may have manifested itself as an unwillingness to listen to outside advice.

V.B. Gender and group confidence

The results in this paper and the recent work of Gneezy, Niederle, and Rustichini (2003) and Gneezy and Rustichini (2004) suggest some interesting directions for future research. In those experiments, subjects perform equally well on a task when competition is not involved. When competition is introduced, the male subjects significantly increase their performance, while the female subjects do not.

Likewise, Niederle and Vesterlund (2006) use an experiment to conclude that men choose to compete too often and women choose to compete too infrequently. Perhaps groups could reduce this competition gap between men and women just as groups reduce the confidence gap in this experiment. In other words, greater confidence appears to be an important reason why men are more likely than women to pursue competitive careers such as entrepreneurship.

⁷Our experiment and other research suggest that these costs of group overconfidence, like the costs of individual overconfidence, are likely to be less severe when groups face a non-familiar problem (Hoelzl and Rustichini, 2005). For example, Apple Computer may have been more willing to listen to outside advice about the design of its headquarters (a non-familiar task) than it was about its decisions relating to the computer industry (a familiar task).

One of the ways that women could enter these competitive fields and men could reduce their excessive entry is by forming teams whenever possible. Our results show that male-female differences in individual confidence may disappear or reverse when groups are involved.

Appendix: Experimental Instructions

Instructions for Lab Experiment

A. Lemonade stand task

Thank you for participating in this experiment about decision-making. In addition to your show-up fee, you can earn more money through your decisions in this experiment. How much you earn will depend on the decisions that you make.

By participating in the experiment, you are agreeing to abide by all of the rules of the experiment. As we read all the instructions, please read along.

These rules include:

- 1) There is no talking allowed at any point during the experiment. The only exception to this is if you have a question. You are encouraged to ask questions if there is anything that is unclear to you. If you have a question, please raise your hand.
- 2) You may not discuss the details of this experiment with anyone after the experimental session is over. Your compliance with this rule is essential for the integrity of our analysis.

In the first part of this experiment, you will operate a lemonade stand and try to make the most profit that you can over a period of three days. You will need to decide how much lemonade to make and what price to charge on each day.

On certain days, the price of lemons and sugar change and so it costs you a different amount to make a glass of lemonade. Also, some days it is rainy and consumers demand less lemonade. Other days, it is sunny and consumers demand more lemonade. On cloudy days, consumers demand more lemonade than on rainy days, but less than on sunny days.

Below are three examples of situations that faced a producer, the decisions that he/she made, and the outcomes that occurred. You can use these examples to help determine what you should choose for the amount and price of the lemonade you produce.

Situation 1:

Situation 1	Outcome from decision
Weather: Cloudy Cost to make one cup of lemonade: \$0.10 Assets you have: \$5.00	Cups sold: 13 Price of a cup: \$0.25 Total revenue: \$3.25
<i>Person A's decision:</i> Price: \$0.25 Production: 20 cups	Cups made: 20 Cost of making a cup: \$0.10 Total cost: \$2.00
<hr/>	
Profit = Revenue - Cost = \$3.25 - \$2.00 = <u>\$1.25</u>	

Situation 2:

Situation 2	Outcome from decision
Weather: Sunny Cost to make one cup of lemonade: \$0.08 Assets you have: \$5.00	Cups sold: 38 Price of a cup: \$0.25 Total revenue: \$9.50
<i>Person A's decision:</i> Price: \$0.25 Production: 50 cups	Cups made: 50 Cost of making a cup: \$0.08 Total cost: \$4.00
<hr/>	
Profit = Revenue - Cost = \$9.50 - \$4.00 = <u>\$5.50</u>	

Situation 3:

Situation 3	Outcome from decision
Weather: Rainy Cost to make one cup of lemonade: \$0.12 Assets you have: \$5.00	Cups sold: 13 Price of a cup: \$0.15 Total revenue: \$1.95
<i>Person A's decision:</i> Price: \$0.15 Production: 20 cups	Cups made: 20 Cost of making a cup: \$0.12 Total cost: \$2.40
<hr/>	
Profit = Revenue - Cost = \$1.95 - \$2.40 = - <u>\$0.45</u>	

Before you run your lemonade stand, you will answer a series of questions about your expectations relating to the task. There are no right or wrong answers to any of the questions about your expectations. You should just answer in a way that reflects what you believe will happen on the lemonade stand task.

Now you will be presented with a series of problems about your expectations relating your decisions as a lemonade stand owner. We will pick one of the choice problems in this experiment at random to determine your payment. Consider the following example:

Sample choice problem:

Option 1: You win if you correctly call a coin flip. In other words, you have a 50% chance of winning. If you pick this option, we will give you a 50% chance of winning.

Option 2: You win if you earn more than \$3 in profit on Day 1.

Your choice (Circle one): Option 1 Option 2

Suppose that this problem is chosen to be the problem for which you are paid. If you chose option 1, we will give you a 50% chance of winning \$5. You can think of us flipping a coin on your behalf. Half of the time, you will win \$5.

If you chose option 2, you will win \$5 if you earned more than \$3 in profit on Day 1. It makes sense to choose option 2 if you think there is at least a 50% chance you will earn more than \$3 in profit on Day 1.

You will have seven minutes to answer these questions.

B. Math Test

Now you will take a skills test that has 6 questions. You will have 10 minutes to complete the test. Here are two sample questions from the test:

Sample problem 1:

6 people meet for a business lunch. Each person shakes hands once with each other person present. How many handshakes take place?

- A) 12 B) 15 C) 18
D) 21 E) 24

Answer: B) Number the six people 1 through 6. Person 1 can shake hands with 5 different people. Then Person 2 can shake hands with 4 people (Persons 3, 4, 5, and 6). Person 3 can shake hands with 3 people, and so on. We end up with a total of:

$$5+4+3+2+1 = 15 \text{ handshakes.}$$

Sample problem 2:

The interior dimensions of a rectangular fish tank are 4 feet long, by 3 feet wide, by 2 feet high. The water level in the tank is 1 foot high. All of this water is poured into an empty second tank. If the dimensions of the second tank are 3 feet long, by 2 feet wide, by 4 feet high, what is the height of the water in the second tank?

- A) 0.5 ft B) 1 ft C) 1.5 ft
D) 2 ft E) 4 ft

*Answer: D) 2 ft. The total volume of water is 12 cubic ft (4 feet long * 3 feet wide * 1 foot tall). We know that the volume of water doesn't change when it is poured into the new tank. So the water will be 2 feet high, since (3 feet long * 2 feet wide * 2 feet high) = 12 cubic feet.*

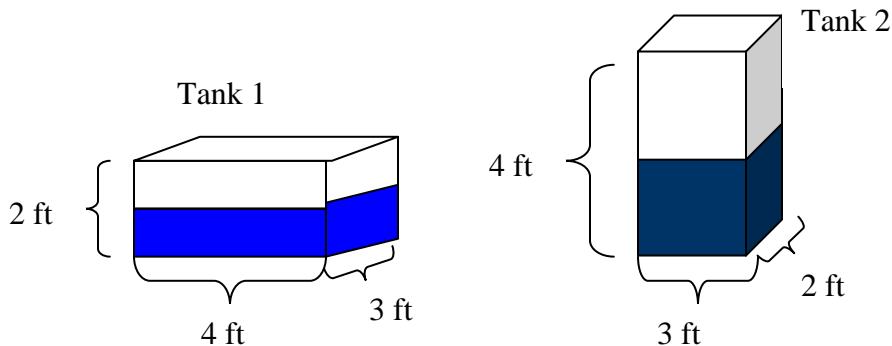

Before you take the skills test, you will answer a series of questions about your expectations relating to the test. There are no right or wrong answers to any of the questions about your

expectations. You should just answer in a way that reflects what you believe will happen on the test.

You have two minutes to answer the following questions.

1) How many questions out of the 6 do you think you will answer correctly?

ANSWER: _____

2) How many questions out of the 6 do you think all other students (not including you) will answer correctly, on average?

ANSWER: _____

3) How many questions out of the 6 do you think that other Honors students (not including you) will answer correctly, on average?

ANSWER: _____

Now you will be presented with another series of problems about your expectations relating to the skills test. We will pick one of the choice problems in this experiment at random to determine your payment. Consider the following example:

Sample choice problem:

Option 1: You win if you correctly call a coin flip. In other words, you have a 50% chance of winning. If you pick this option, we will give you a 50% chance of winning.

Option 2: You win if you answer Question 1 on the skills test correctly.

Your choice (Circle one): Option 1 Option 2

Suppose that this problem is chosen to be the problem for which you are paid. If you chose option 1, we will give you a 50% chance of winning \$5. You can think of us flipping a coin on your behalf. Half of the time, you will win \$5.

If you chose option 2, you will win \$5 if you answered Question 1 correctly. It makes sense to choose option 2 if you think there is at least a 50% chance you will answer Question 1 correctly.

You will have seven minutes to answer these questions.

C. Choice Problems

These three problems below contain the exact wording for the three choices that subjects made that are analyzed in the paper. The wording for the math test is the same except the choices referred to the number of problems solved instead of the profit made.

Below is a list of the groups that are participating in the experiment. Each group was invited to participate in the experiment in the same way.

(Groups listed here)

Choice problem 1:

Option 1: You win if you correctly call a coin flip. In other words, you have a 50% chance of winning. If you pick this option, we will give you a 50% chance of winning.

Option 2: You win if you earn more profit than half of the other students in the experiment. It makes sense to choose Option 2 if you think there's a better than 50% chance that your total profits will be in the top half of all total profits. Any ties will be randomly broken.

Your choice (Circle one): Option 1 Option 2

Choice problem 2:

Option 1: You win if you correctly call a coin flip. In other words, you have a 50% chance of winning.

Option 2: You win if you earn more profit than half of the other (subject's group name here) students in the experiment. Any ties will be randomly broken.

Your choice (Circle one): Option 1 Option 2

Choice problem 3:

Option 1: You win if you correctly call a coin flip. In other words, you have a 50% chance of winning.

Option 2: You win if the other (subject's group name here) students' average profit is higher than the average profit of all other students in the experiment. Any ties will be randomly broken.

Your choice (Circle one): Option 1 Option 2

Instructions for Field Experiment

Survey of Scrabble players

In this survey, you will be asked to answer a series of questions about your expectations relating to this tournament. All of your answers will be kept confidential. Five participants will be randomly selected to **win cash prizes based on the accuracy of their predictions** about what will happen in the tournament. If you are selected, you will receive \$4 for each question about your expectations that you answer correctly. Winners will be notified by e-mail after the tournament. Thank you for participating!

General information:

Name: _____ Age: _____
 E-mail: _____ Gender (circle): Male Female

Personal expectations:

How many games will you win in the main event? _____ out of 28
 Will your rating be higher or lower after the tournament than it is now? Higher Lower

	Club A	Club B	Club C
How many times per month do you play in this club?	0-2 3-5 6 or more	0-2 3-5 6 or more	0-2 3-5 6 or more
Are other players from this club playing in the tournament?	Yes No/Don't know	Yes No/Don't know	Yes No/Don't know
Will the mean rating of the club's players (including yourself) be higher or lower?	Higher Lower	Higher Lower	Higher Lower
Will the mean rating of the club's players (NOT including yourself) be higher or lower?	Higher Lower	Higher Lower	Higher Lower

Name up to three friends or acquaintances (people whom you know personally) who are also playing in the main event and indicate your expectations for their performances:

Friend 1: Name: _____ Games your friend will win? _____ out of 28
 Rating will be higher or lower after the tournament? Higher Lower

Friend 2: Name: _____ Games your friend will win? _____ out of 28
 Rating will be higher or lower after the tournament? Higher Lower

Friend 3: Name: _____ Games your friend will win? _____ out of 28
 Rating will be higher or lower after the tournament? Higher Lower

References

- Barber, Brad and Terrence Odean (2001). "Boys Will Be Boys: Gender, Overconfidence, and Common Stock Investment," *Quarterly Journal of Economics*, 116, 261-292.
- Benabou, Roland and Jean Tirole (2002). "Self-Confidence and Personal Motivation," *Quarterly Journal of Economics*, 117, 871-915.
- Bengtsson, Claes, Mats Persson, and Peter Willenhag (2005). "Gender and Overconfidence," *Economics Letters*, 86, 199-203.
- Blinder, Alan S. and John Morgan (2005). "Are Two Heads Better Than One? Monetary Policy By Committee," *Journal of Money, Credit, and Banking*, 37, 789-812.
- Burrows, Peter (2000). "Apple; Yes, Steve, You Fixed It. Congrats! Now What's Act Two?" *Business Week*, 3692, 102-112.
- Camerer, Colin and Dan Lovallo (1999). "Overconfidence and Excess Entry: An Experimental Approach," *American Economic Review*, 89/1, 306-318.
- Daniel, Kent, David Hirshleifer, and Avanidhar Subrahmanyam (1998). "Investor Psychology and Security Market Over- and Under-Reactions," *Journal of Finance*, 53, 1839-1886.
- Doeringer, Peter and Michael Piore (1971). *Internal Labor Markets and Manpower Analysis*. Lexington, MA: Heath.
- Dunning, David, Judith Meyerowitz, and Amy Holzberg (1989). "Ambiguity and Self-Evaluation: The Role of Idiosyncratic Trait Definitions in Self-Serving Assessments of Ability," *Journal of Personality and Social Psychology*, 6, 1082-1090.
- Gigerenzer, Gerd, U. Hoffrage, and H. Kleinbolting (1991). "Probabilistic Mental Models: A Brunswikian Theory of Confidence," *Psychological Review*, 98, 506-528.
- Gneezy, Uri, Muriel Niederle, and Aldo Rustichini (2003). "Performance in Competitive Environments: Gender Differences," *Quarterly Journal of Economics*, 118, 1049-1074.
- Gneezy, Uri and Aldo Rustichini (2004). "Gender and Competition at a Young Age," *American Economic Review Papers and Proceedings*, 377-381.
- Granovetter, Mark (1973). "The Strength of Weak Ties," *American Journal of Sociology*, 78, 1360-1380.
- Greico, Daniela and Robin Hogarth (2004). "Excess Entry, Ambiguity Seeking, and Competence," working paper.
- Griffin, Dale and Amos Tversky (1992). "The Weighting of Evidence and the Determinants of Confidence," *Cognitive Psychology*, 24, 411-435.
- Healy, Andrew (2006). "Do People Appreciate the Value of Listening to a Variety of Different Opinions?" Loyola Marymount University working paper.
- Hoelzl, Erik and Aldo Rustichini (2005). "Overconfident: Do You Put Your Money on It," *Economic Journal*, 115, 305-318.
- Hoorens, V. and B.P. Buunk (1993). "Social Comparison of Health Risks: Locus of Control, the Person-Positivity Bias, and Unrealistic Optimism," *Journal of Applied Social Psychology*, 23, 291-302.
- Janis, Irving L. (1972). *Victims of Groupthink: A Psychological Study of Foreign Policy Decisions and Fiascoes*. Boston, MA: Houghton-Mifflin.
- Klar, Yecheil and Eilath Giladi (1997). "No One in My Group Can Be Below the Group's Average: A Robust Positivity Bias in Favor of Anonymous Peers," *Journal of Personality and Social Psychology*, 73, 885-901.
- Koszegi, Botond (2005). "Ego Utility, Information Acquisition, and Task Choice," forthcoming,

Journal of the European Economic Association.

- Landry, John (1997). "If an Organization Has a Memory, Will it Need a Therapist?" *Proceedings of the 13th Annual Hawaii International Conference on System Sciences*, 1-9.
- McAnear, T. Paul and Elaine Seat (2001). "Perceptions of Team Performance: A Comparison of Male and Female Engineering Students," proceedings of the 31st ASEE/IEEE Frontiers in Education Conference.
- Montgomery, James (1991). "Social Networks and Labor Market Outcomes: Toward an Economic Analysis," *American Economic Review*, 1408-1418.
- Niederle, Muriel and Lise Vesterlund (2006). "Do Women Shy Away From Competition? Do Men Compete Too Much?" forthcoming, *Quarterly Journal of Economics*.
- Norsworthy, J.R. and Craig Zabala (1985). "Worker Attitudes, Worker Behavior, and Productivity in the U.S. Automobile Industry," *Industrial and Labor Relations Review*, 544-557.
- Perloff, L. and B. Fetzer (1986). "Self-Other Judgments and Perceived Vulnerability to Victimization," *Journal of Personality and Social Psychology*, 50, 502-510.
- Renner, Catherine Hackett and Michael J. Renner (2001). "But I Thought I Knew That: Using Confidence Estimation as a Debiasing Technique to Improve Classroom Performance," *Applied Cognitive Psychology*, 15, 23-32.
- Surowiecki, James (2004). *The Wisdom of Crowds*. New York, NY: Doubleday.
- Svenson, Ola (1981). "Are We All Less Risky and More Skillful Than Our Fellow Drivers?" *Acta Psychologica*, 47, 143-148.
- Wanous, John (1980). *Organizational Entry*. Reading, MA: Addison-Wesley.